

ಬೆಳಗಾವಿ ಸ್ಮಾರ್ಟ್‌ಸಿಟಿ ನಿಯಮಿತ

1ನೇ ಮಹಡಿ, ಬುಡಾಕಚೇರಿ,
ಆಶೋಕ ನಗರ, ಬೆಳಗಾವಿ-590 006.
ದೂರವಾಣಿ ಸಂ:0831-2461352.



BELAGAVI SMART CITY LIMITED

1st Floor, BUDA Office,
Ashok Nagar, Belagavi-590 006.
Phone No.: 0831-2461352.

Website: www.belagavismartcity.in, Email: bscltd16@gmail.com TAN: BLRB14232B PAN: AAGCB9785J CIN: U74999KA2016PLC093099

ಸಂಖ್ಯೆ: ಬೆಸ್ಕಾಸಿಲಿ/ಕೋಟೇಷನ್ ನೋಟಿಫಿಕೇಷನ್/ಟಿ.ಎಸ್/2023-24/376

ದಿನಾಂಕ: 01-08-2023

ಇವರಿಗೆ,

ಉಪನಿರ್ದೇಶಕರು,

ವಾರ್ತಾ ಮತ್ತು ಪ್ರಚಾರ ಇಲಾಖೆ,

ಬೆಳಗಾವಿ.

ವಿಷಯ: ಬೆಳಗಾವಿ ಸ್ಮಾರ್ಟ್‌ಸಿಟಿ ಲಿಮಿಟೆಡ್, ಕಛೇರಿಗೆ ಸಾರ್ವಜನಿಕ ಖಾಸಗಿ ಸಹಭಾಗಿತ್ವದಲ್ಲಿ
ಲೇಬಲಿಂಗ್ ಸ್ಟ್ಯಾಟಿಜಿಯಡಿ ರೇಡಿಯಮ್ ಸ್ಥಿಕರಿಂಗೊಂದಿಗೆ ಫಲಕಗಳನ್ನು ಅಳವಡಿಸುವ
ಕೋಟೇಷನ್ ರೇಟ್ಸ್ ಪತ್ರಿಕೆಯಲ್ಲಿ ಪ್ರಕಟಿಸುವ ಕುರಿತು.

ಮೇಲ್ಕಾಣಿಸಿದ ವಿಷಯಕ್ಕೆ ಸಂಬಂಧಿಸಿದಂತೆ, ಬೆಳಗಾವಿ ಸ್ಮಾರ್ಟ್‌ಸಿಟಿ ಲಿಮಿಟೆಡ್ ಯೋಜನೆಯಡಿ ಈ ಕೆಳಕಂಡ
ಲೇಬಲಿಂಗ್ ಸ್ಟ್ಯಾಟಿಜಿಯಡಿ ರೇಡಿಯಮ್ ಸ್ಥಿಕರಿಂಗೊಂದಿಗೆ ಫಲಕಗಳನ್ನು ಅಳವಡಿಸುವ ಕೋಟೇಷನ್ ರೇಟ್ಸ್ ಪತ್ರಿಕೆಯಲ್ಲಿ
ಈ ಕುರಿತಾದ ವಿವರವನ್ನು ಈ ಪತ್ರದೊಂದಿಗೆ ಲಗತ್ತಿಸಿದ್ದು, ಸದರಿ ಟೆಂಡರ್ ಪ್ರಕಟಣೆಯನ್ನು ರಾಜ್ಯಮಟ್ಟದ ಒಂದು ಕನ್ನಡ
ಮತ್ತು ಇಂಗ್ಲೀಷ್ ದಿನಪತ್ರಿಕೆಯಲ್ಲಿ ಒಂದು ಬಾರಿ ಕಡಿಮೆ ಸ್ಥಳಾವಕಾಶದಲ್ಲಿ ಪ್ರಕಟಿಸಲು ಕೋರಲಾಗಿದೆ. ಸದರಿ ಪ್ರಕಟಣೆಯ
ವೆಚ್ಚವನ್ನು ಈ ಕಛೇರಿಯಿಂದ ಭರಿಸಲಾಗುವುದು.

ಅಡಕ: ಟೆಂಡರ್ ಅಧಿಸೂಚನೆ ಪ್ರಕಟಣಾ ಪ್ರತಿ.

9
118/23

ತಮ್ಮ ವಿಶ್ವಾಸಿ,

ಶ್ರೀಮತಿ ಉಪನಿರ್ದೇಶಕರು (ಮ್ಯಾನ್ಯೂರಲ್)
ವ್ಯವಸ್ಥಾಪನಾ ಮತ್ತು ಸಂಪರ್ಕ ವಿಭಾಗ
ಬೆಳಗಾವಿ ಸ್ಮಾರ್ಟ್‌ಸಿಟಿ ಲಿಮಿಟೆಡ್,
ಬೆಳಗಾವಿ.
Dpt. of Information & Public Relations
Court Compound, Belagavi-590002



ಬೆಳಗಾವಿ ಸ್ಟಾರ್ಟ್ ಸಿಟಿ ನಿಯಮಿತ

1 ನೇ ಮಹಡಿ, ಬುಡಾಕಚೇರಿ, ಅಶೋಕ ನಗರ, ಬೆಳಗಾವಿ -590016.

Phone: 0831-2461352, E-mail: bscltd16@gmail.com, website: www.bscl.in

ದರಪಟ್ಟಿ/ಅಂದಾಜುಪಟ್ಟಿ ಆಹ್ವಾನ ಪ್ರಕಟಣೆ

ದಿನಾಂಕ: 31/07/2023

ಕ್ರ. ಬಿ.ಎಸ್.ಸಿ.ಎಲ್/ಟಿ.ಎಸ್/ಟೆಂಡರ್/2023-24/376

ವ್ಯವಸ್ಥಾಪಕ ನಿರ್ದೇಶಕರು, ಬೆಳಗಾವಿ ಸ್ಟಾರ್ಟ್ ಸಿಟಿ ನಿಯಮಿತ ಬೆಳಗಾವಿ ಇವರ ಪರವಾಗಿ ಉಪಪ್ರಧಾನ ವ್ಯವಸ್ಥಾಪಕರು (ಪ್ರೊಕ್ಯೂರಮೆಂಟ್) ಇವರು "ಬೆಳಗಾವಿ ಸ್ಟಾರ್ಟ್ ಸಿಟಿ ಯೋಜನೆಗಳಿಗೆ ಲೇಬಲಿಂಗ್ ಸ್ಟ್ಯಾಟಿಜಿಯಡಿ ರೇಡಿಯಮ್ ಸ್ವೀಕರಿಂಗೊಂದಿಗೆ ಫಲಕಗಳನ್ನು ಅಳವಡಿಸುವ ಕಾಮಗಾರಿಗೆ ಅರ್ಹ ಸಂಸ್ಥೆಗಳಿಂದ ದರಪಟ್ಟಿ/ ಕೊಟೀಷನ್‌ಗಳನ್ನು ಆಹ್ವಾನಿಸಲಾಗಿದೆ. ಸಲ್ಲಿಸುವ ದರಗಳನ್ನು ಅಂದಾಜು ಪಟ್ಟಿ ಸಿದ್ಧಪಡಿಸುವುದಕ್ಕಾಗಿ ಮಾತ್ರ ಪರಿಗಣಿಸಲಾಗುತ್ತದೆ. ಅರ್ಹಗುತ್ತಿಗೆದಾರರು/ ವಿಜೆನ್/ ಮಾದಾಟಗರರು ಸ್ಪರ್ಧಾತ್ಮಕ ದರಗಳನ್ನು ಮುಚ್ಚಿದ ಲಕೋಟಿಯಲ್ಲಿ ಉಪಪ್ರಧಾನ ವ್ಯವಸ್ಥಾಪಕರು (ಪ್ರೊಕ್ಯೂರಮೆಂಟ್) ಬೆಳಗಾವಿ ಸ್ಟಾರ್ಟ್ ಸಿಟಿ ಲಿಮಿಟೆಡ್, ಬೆಳಗಾವಿ, ಅಶೋಕ ನಗರ, ಬುಡಾಕಚೇರಿ, 1ನೇ ಹಂತ, ಬೆಳಗಾವಿ ಇಲ್ಲಿಗೆ ದಿನಾಂಕ: 07-08-2023 ರಂದು ಸಂಜೆ 4:00 ಗಂಟೆಯೊಳಗಾಗಿ ಸಲ್ಲಿಸತಕ್ಕದ್ದು. ರೇಡಿಯಮ್ ರೇಡಿಯಮ್ ಸ್ವೀಕರಿಂಗ್ ಮತ್ತು ಫಲಕಗಳ ವಿಶಿಷ್ಟತೆ/ವಿವರಗಳು ಮತ್ತು ನಮೂನೆಗಳನ್ನು www.bscl.in ನಿಂದ ಪಡೆಯಬಹುದಾಗಿರುತ್ತದೆ.

-Sd-

ಉಪಪ್ರಧಾನ ವ್ಯವಸ್ಥಾಪಕರು (ಪ್ರೊಕ್ಯೂರಮೆಂಟ್)
ಬೆಳಗಾವಿ ಸ್ಟಾರ್ಟ್ ಸಿಟಿ ನಿಯಮಿತ, ಬೆಳಗಾವಿ.

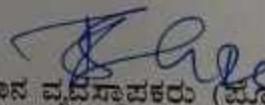
ಉಪಪ್ರಧಾನ ವ್ಯವಸ್ಥಾಪಕರು (ಪ್ರೊಕ್ಯೂರಮೆಂಟ್)
ಬೆಳಗಾವಿ ಸ್ಟಾರ್ಟ್ ಸಿಟಿ ನಿಯಮಿತ, ಬೆಳಗಾವಿ



BELAGAVI SMART CITY LIMITED
1st Floor, BUDA Office, Ashok Nagar, Belagavi -590016.
Phone: 0831-2461352, E-mail: bscltd16@gmail.com, website: www.belagavismartcity.in

Notice Inviting Quotation Notification

Tender No: BSCl/Quotation/Labelling/2023-24/376

Date: 31/07/2023

On behalf of the Managing Director, Belagavi Smart City Limited invites rates quotation for "Supply, Installation and Commissioning Signages with Labeling for Smart City Works in Belagavi City". Vendors can submit their rate quotation inclusive of all taxes before 4.00 pm on 07.08.2023. Further details may be downloaded from the BSCl website www.bscl.in For more information, vendors may contact BSCl office during working hours at Belagavi Smart City Ltd, 1st floor BUDA Office, Ashok Nagar, Belagavi, Email id bscltd16@gmail.com Vendor are requested to submit had copies of competitive rates in closed with sealed envelope to the Managing Director, Belagavi Smart City Limited, Belagavi office:

-sd-

Deputy General Manager (Procurement)
Belagavi Smart City Limited

Deputy General Manager (Procurement)
Belagavi Smart City Limited.

ಬೆಳಗಾವಿ ಸ್ಮಾರ್ಟ್‌ಸಿಟಿ ನಿಯಮಿತ

ಕಛೇರಿ: ಮಹಾನಗರ ಪಾಲಿಕೆ ಕಛೇರಿ: ಸಿ.ಟಿ.ಎಸ್. ನಂ:
ಗುರುವಾರ ಪೇಠ, ಟಿಲಕ್‌ವಾಡಿ, ಬೆಳಗಾವಿ -590 006.
ದೂರವಾಣಿ ಸಂ.: 0831-2461352.



BELAGAVI SMART CITY LIMITED

197,Office: City Corporation office at C.T.S. No: 197,
Guruwar Peth, Tilakwadi, Belagavi-590 006.
Phone No.: 0831-2461352.

Website: www.belagavismartcity.in Email: bscltd16@gmail.com TAN: BLRB14232B PAN: AAGCB9785J CIN: U74999KA2016PLC09309

No.BSCL/Quotation/BSCL-Labeling / 2023-24/ 376

Date: 31- 07 - 2023

Quotation Notification

Belagavi Smart City Limited invites quotations for “Supply, Installation and Commissioning Signages with Labeling for Smart City Works in Belagavi City”. Eligible Consultant can submit their quotations through speed post/register post/ By hand on or before 05-08-2023 up to 4.30 pm inclusive of all taxes. For more information Consultant may contact BSCL office during working hours.

Logo Sign-B1	Quotation Rate (per Unit)						
<div data-bbox="365 852 846 1140"></div> <table border="1" data-bbox="375 1203 857 1409"><thead><tr><th>Logo Sign</th><th>Dimensions (mm)</th></tr></thead><tbody><tr><td>B-1a</td><td>X=1000, Y=500</td></tr><tr><td>B-1b</td><td>X=400, Y=200</td></tr></tbody></table>	Logo Sign	Dimensions (mm)	B-1a	X=1000, Y=500	B-1b	X=400, Y=200	
Logo Sign	Dimensions (mm)						
B-1a	X=1000, Y=500						
B-1b	X=400, Y=200						
Item Specification							
Retro-Reflectorised Signs Providing and fixing of retro – reflectorised designed logo and informatory sign as per IRC:67 made of high intensity grade sheeting on concrete/ metal/ glass/ wooden surfaces. Item includes cost of all materials, loading, unloading, lead, lift, transportation and any incidental charges etc.complete as per direction of Engineer In-Charge. work confirming to clause 6.7 & (Table No- 6.2) of IRC 67-2012 for Type XI retro reflective sheeting from the sheeting manufacturer & a certified copy of test reports from an independent test laboratory conforming to clause 6.9 of IRC 67-2012, MORTH vide Clause 801.3 and ASTM D4956							

Logo Sign-B2	Quotation Rate (per Unit)
---------------------	--------------------------------------

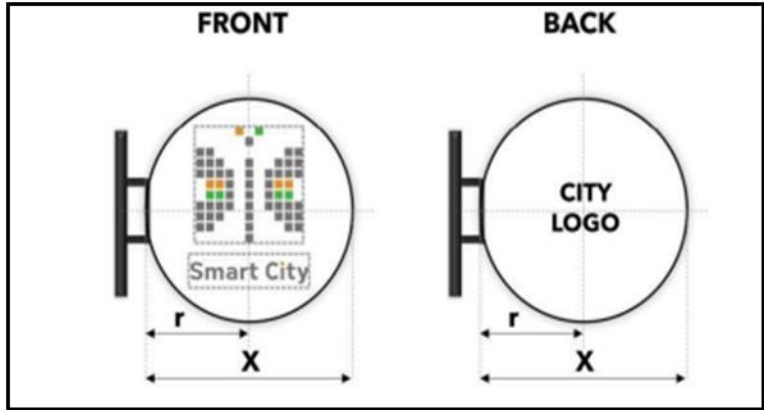

Logo Sign	Dimensions (mm)
B-2	X=300, r=150

Details of U-Bolt for clamping the pole

Material	
U-bolt	Carbon steel
Nuts	
Surface finish	

- Material should match
- 1) Chemical properties as per IS 1030 table-01
 - 2) Mechanical properties as per IS 1030 table-02

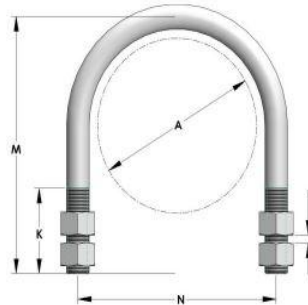

M-20 U-bolt of required size according to the existing pole 9m/7m.

Item Specification

Retro-Reflectorised Signs

Providing and fixing of retro – reflectorised designed logo and informatory sign as per IRC:67 made of high intensity grade sheeting, affixed onto a 1.5mm thick circular aluminium sheet on both sides. The circular sign board supported by two horizontal square hollow section of 35x35x3.2mm, attached to MS plate of 250x300x4mm and fixed to the existing pole by M-20 U-bolt of required size according to the existing pole 9m/7m. The gaps between the circular sheeting are covered with 1.5mm thick aluminium sheeting, providing a smooth edge finish, and the entire assembly is coated with powder coated paint. Item includes cost of all materials, bolting, fixing, welding, soldering, reworking, loading, unloading, lead, lift, transportation and any incidental charges etc. Complete as per direction of Engineer In-Charge. Work conforming to clause 6.7 & (Table No- 6.2) of IRC 67-2012 for Type XI retro reflective sheeting from the sheeting manufacturer & a certified copy of test reports from an independent test laboratory conforming to clause 6.9 of IRC 67-2012, MORTH vide Clause 801.3 and ASTM D4956

Logo Sign-B3

**Quotation
Rate (per
Unit)**

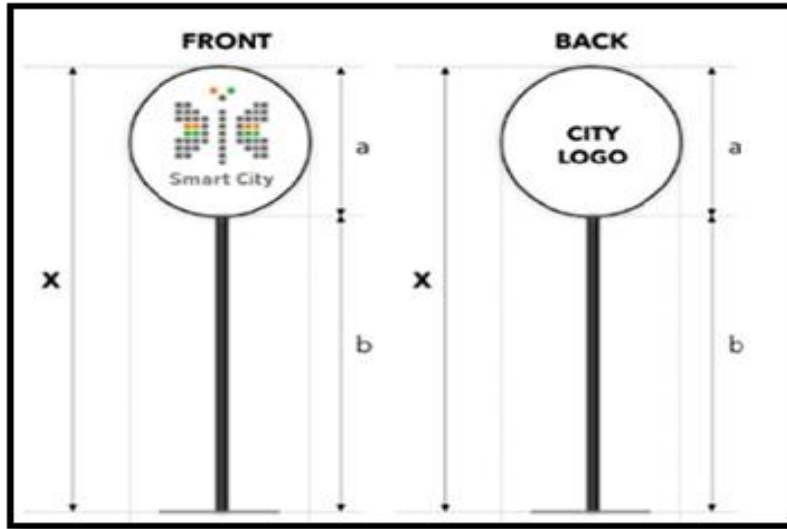

Logo Sign	Dimensions (mm)
B-3	X=2000, b=1700, a=300

Item Specification

Retro-Reflectorised Signs

Providing and fixing of retro – reflectorised designed logo and informatory sign as per IRC:67 made of high intensity grade sheeting, fixed over circular aluminium sheeting 1.5 mm thick both side, supported on a MS Verticle Circular pole-60NB, 76.1OD,3.2mm thk and firmly fixed to the ground by means of properly designed foundation with M 20 grade cement concrete (mix proportion 1:1.5:3) 450mmx450mmx900mm over a 100mm thick P.C.C (M10) bed, post should embed in concrete 90 Cm below ground level with cross anchorage supports. Aluminium sheeting of 1.5mm thick to be coverd between gaps of the circular sheet of smooth edge finishing and the entire assembly is coated with powder coated paint. Item includes earthwork excavation, cost of all materials, welding (arch welding minimum 6mm thick), soldring, revetting, loading, unloading, lead, lift, transportation and any incidental charges etc.complete as per direction of Engineer In-Charge. work confirming to clause 6.7 & (Table No- 6.2) of IRC 67-2012 for Type XI retro reflective sheeting from the sheeting manufacturer & a certified copy of test reports from an independent test laboratory conforming to clause 6.9 of IRC 67-2012, MORTH vide Clause 801.3 and ASTM D4956

Logo Sign-B4

Quotation Rate (per Unit)

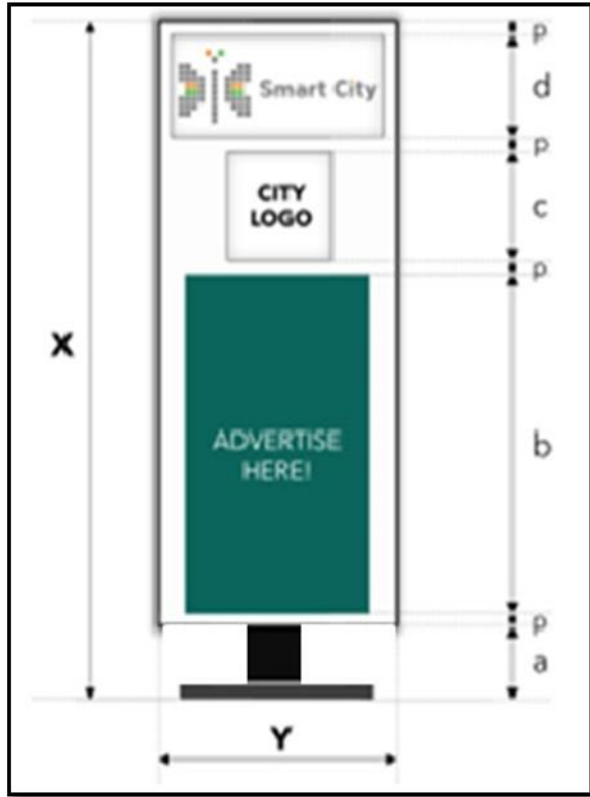

Variables	Dimensions (mm)
X	2400
Y	500
a	300
b	1500
c	200
d	200
p	50

Table -1: Structural details for fixing the Sign board

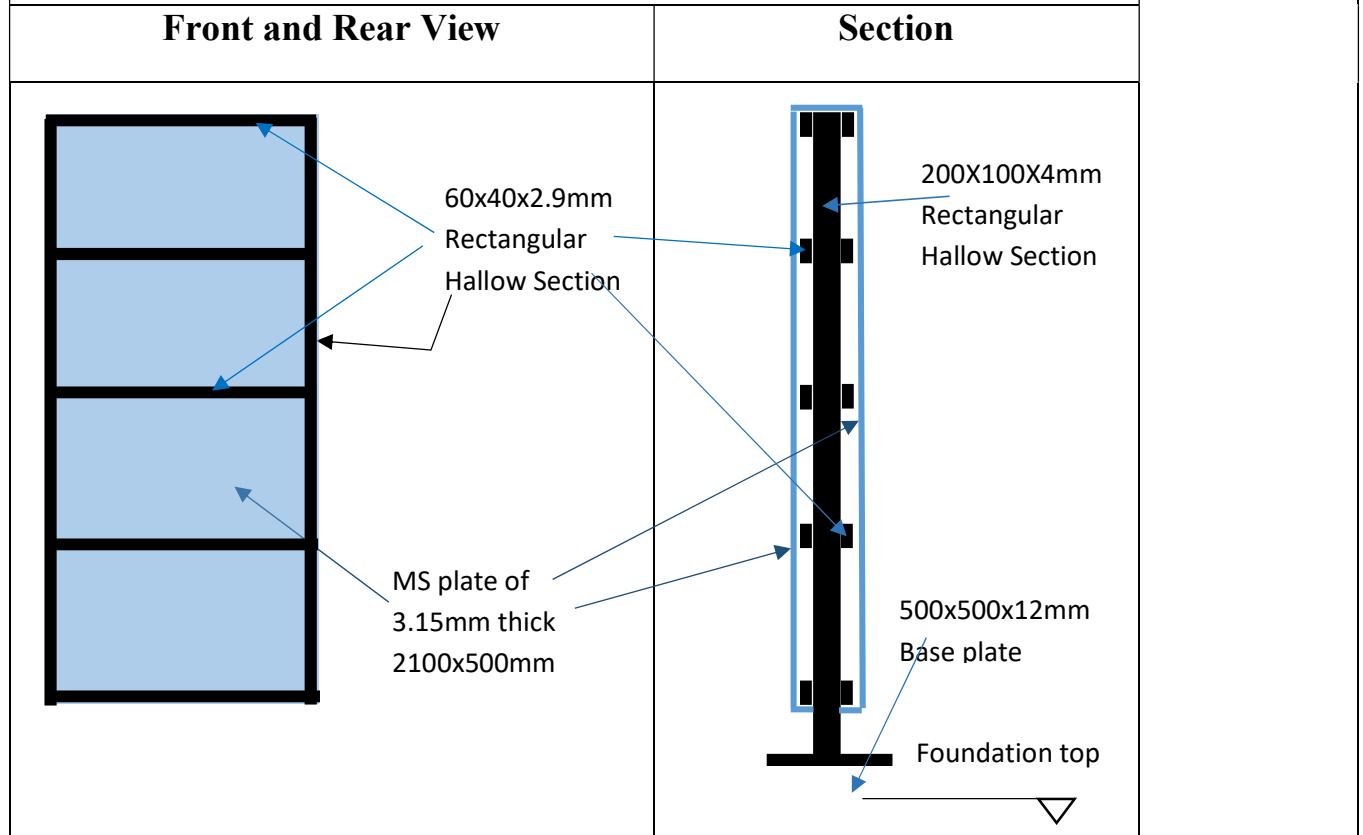

Foundation details For Logo Sign-B4

Table-2: Footing details of Logo sign boad –B4

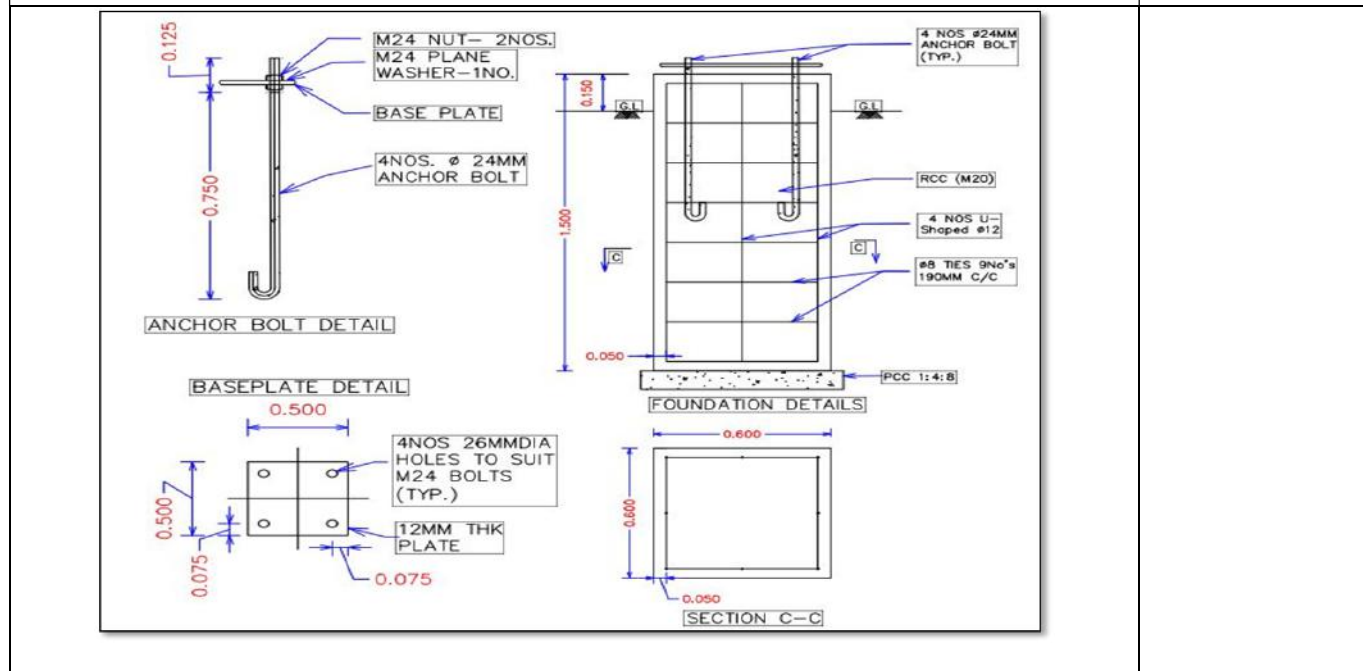

Item Specification	
<p>Retro-Reflectorised Signs</p> <p>Supply and Installation of retro-reflective designed logos and informative signs, in accordance with IRC:67 specifications, utilizing high-intensity grade sheeting. The logos and signs are mounted on an MS rectangular plate measuring 2100X500X3.15mm, supported by a 60X40X2.9mm frame structure, and firmly attached to a vertical rectangular hollow section of dimensions 200X100X4mm. This assembly is securely mounted on a base plate measuring 500X500X12mm, using a properly designed foundation with M20 grade cement concrete (mix proportion 1:1.5:3) over a 100mm thick P.C.C (M10) bed. J bolts, as per the provided drawing, are used for fastening. To fill the gaps between the rectangular board with smooth edge finishing, MS sheet of 3.15 mm thickness is used, and the entire structure is coated with powder-coated paint. The structural and foundation details are provided in table-01 and table 02 respectively. Item includes earthwork excavation, cost of all materials, welding (arch welding minimum 6mm thick), soldering, revetting, loading, unloading, lead, lift, transportation and any incidental charges etc. complete as per direction of Engineer In-Charge. work confirming to clause 6.7 & (Table No- 6.2) of IRC 67-2012 for Type XI retro reflective sheeting from the sheeting manufacturer & a certified copy of test reports from an independent test laboratory conforming to clause 6.9 of IRC 67-2012, MORTH vide Clause 801.3 and ASTM D4956</p>	

- The last date for submission of quotation is: 07 - 08 -2023 up to 4.30 pm
- The quotation shall be opened on the same day

Conditions:

- 1) Cost of Item shall be inclusive of all taxes With all necessary fixing arrangement as per Specification.
- 2) Quality of material as Indian Standard Specification as updated
- 3) Mention the terms and conditions clearly if any
- 4) The quotation should be signed and sealed by concern Consultant adhering to the above points very clearly.

**Duputy General Manager Technicle,
Belagavi Smart City Limited**

